

1. Evaluate  $\frac{b^3 - 21}{5b + 29.897036}$  when  $b = 3.19$ . Write your answer as a reduced common fraction.
2. Let  $ANS$  be the slope of the line passing through  $(22.64, k + 0.1)$  and  $(1.84, -4.1)$ . Find the value of  $k$ .
3.  $\overline{EF}$  is a diameter of a circle. If  $E$  has coordinates  $(ANS, 4)$  and  $F$  has coordinates  $(3, 2)$ , find the exact value of the length of the radius of this circle.
4. Let  $ANS$  be the length of each edge of a regular hexagon. Find the exact area of this regular hexagon.

ANSWERS

1.  $\frac{1}{4}$  (Must be this reduced common fraction.)
2. 1
3.  $\sqrt{2}$  (Must be this exact radical.)
4.  $3\sqrt{3}$  (Must be this exact radical.)

- Solve for  $x$  when  $5x - 3(x - 4) = 18$ .
- Find the sum of the two solutions for  $x$  when  $2|x - ANS| + 1 = 5$ .

- $TRAP$  is a trapezoid with  $\overline{TR} \parallel \overline{AP}$ .  $\angle A$  is a right angle,  $m\angle APR = 52^\circ$ ,  $m\angle ARP = [(ANS)w + 2]^\circ$ , and  $m\angle PRT = (4.134k - 1.742)^\circ$ . Find the sum  $(k + w)$ .

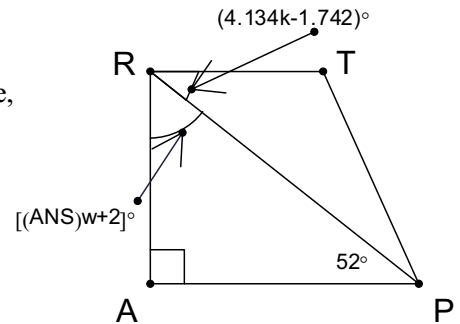

- A clock with hour and minute hands is set to exactly 1:00 PM. Find the measure of the acute angle formed by the hour and minute hands after  $ANS$  minutes elapse. Write your answer as a decimal.

ANSWERS

- 3
- 6
- 19
- 74.5 (Must be this exact decimal, degrees optional.)

1. The ordered pair  $(k, w)$  is the solution to the system where  $y = \frac{1}{2}x$  and  $2x + 3y = -7$ .  
Find the sum  $(k + w)$ .

2.  $\left(\frac{3}{4d}\right)\left(\frac{2d^4}{c^3}\right)(8c^6d^{-3})^{-2}(5c^5)^3(d^{-2})^{ANS} = Nc^k d^w$ . Find the value of  $(k + w)$ .

3. In the diagram,  $\frac{BD}{DA} = \frac{BE}{EC}$ .  $BE = 18$ ,  $EC = 6$ ,  
 $DE = 12$ , and  $BD = ANS$ . Find the perimeter of  
Quadrilateral  $ACED$ .

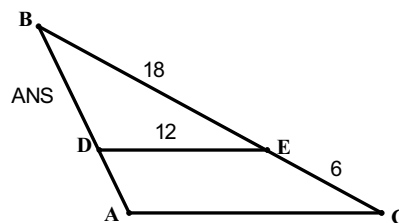

4. Looking directly from the side at a car with 16-inch wheels, the 16-inch wheel appears to be a solid silver circular disk with diameter of 16 inches and the axle is the center. The black rubber tire then extends 5 inches all around the wheel with the top of the tread (tire) forming a concentric circle. Find the total distance a point on the top of the tread travels as it rotates around the axle when the tire makes  $ANS$  revolutions? Write your answer as an integer rounded to the nearest **foot**.

ANSWERS

1. -3  
2. 15  
3. 39 (Units optional.)  
4. 265 (Must be this integer, feet optional.)

- Find the sum of the solutions for the equation  $x^2 - 26 = 11x$ .
- Set  $A = \{ANS, 9, 10, 11, 12, 15, 16\}$ . Let  $C = \{2, 9, 7\}$ . The arithmetic mean of  $C$  is 6 since the average of 2, 9, and 7 is 6. The median of  $C$  is 7 because 7 is the middle data point if the data are arranged in order. Set  $A$  has median  $k$  and arithmetic mean  $w$ . Find the sum  $(k + w)$ .

- In the diagram,  $\overline{HO} \parallel \overline{TA}$ .  $m\angle HOM = 118^\circ$ ,  $m\angle TMS = k^\circ$ ,  $m\angle MAS = w^\circ$ , and  $m\angle MSA = (ANS)^\circ$ . Find the sum  $(k + w)$ .

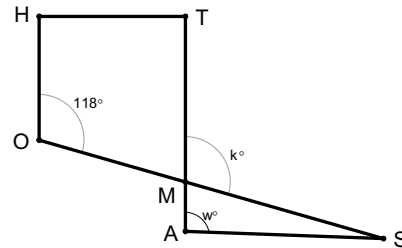

- Given the circle with two secant segments meeting at point  $X$ ,  $\overline{AB} \cong \overline{CD}$  and  $m\widehat{ADC} = (ANS)^\circ$ . Find the degree measure of  $\angle AXD$ .

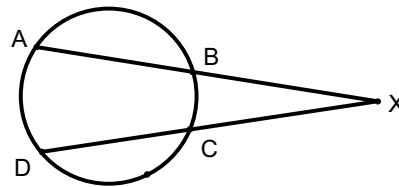

ANSWERS

- 11
- 23
- 213 (Degrees optional.)
- 33 (Degrees optional.)

1. Let  $x$  be a member of  $\{1, 2, 3, 4, 5, 6, 7, 8, 9, 10\}$ . For how many distinct values of  $x$  will the expression  $\left[ x \left( 1 + \frac{1}{2} \right) + 0.5 \right]$  be a whole number?

2. Let  $k = 2(ANS)$ . Solve for  $x$  when  $\frac{2x}{x-1} + \frac{2}{3} = \frac{k}{x-1}$ .

3.  $\triangle MIK$  is a right triangle with  $\overline{MI} \perp \overline{IK}$ .  $\overline{IE} \perp \overline{MK}$  at point  $E$ .  $ME = 12$  and  $KE = ANS$ . Find the exact area of  $\triangle MIK$ .

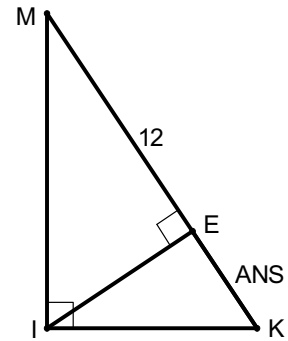

4. Let  $ANS$  represent the numerical area of Rhombus  $RHOM$ . One Angle of  $RHOM$  measures  $45^\circ$ . Find the numerical length of the shorter diagonal of  $RHOM$ . Write your answer as a decimal rounded to the nearest tenth of a unit.

ANSWERS

1. 5  
 2. 4  
 3.  $32\sqrt{3}$  (Must be this exact answer.)  
 4. 6.8 (Must be this decimal, units optional.)